

MEGA

Electrical submersible drainage pump

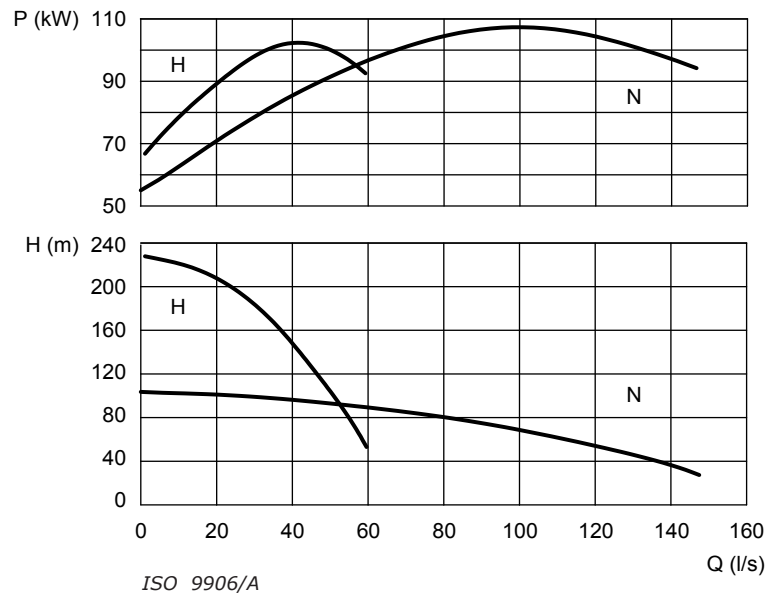
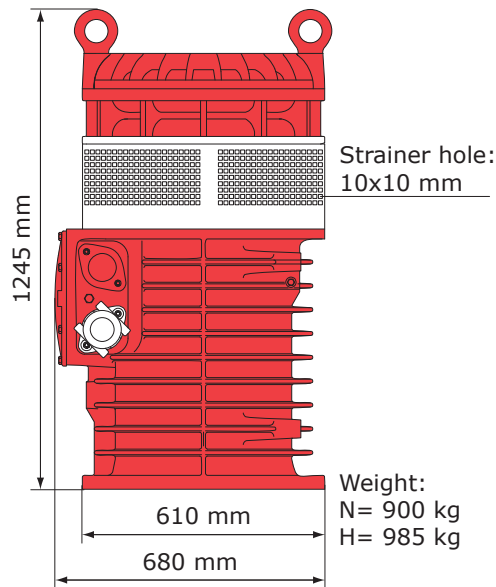

Pump types

N: Normal head
H: High head

Classification

Electrical submersible pump
Protection class: IP68
Max. submersion depth: 75 m

Electrical motor

Squirrel cage 3-phase induction motor
Insulation class: H (IEC 85)

Technical data

Shaft speed	rpm	3560
Rated output	kW	104
Max. power cons.	kW	110
Rated current A at	460 V	149
	575 V	117

Other voltages on request

Motor protector

Temperature guard with thermal contacts in the stator

Monitoring equipment

Pt 100 sensor for main bearing temperature reading

Power cable

SUBCAB 4G25+2x1,5
SUBCAB 4G35+2x1,5
SUBCAB 4G35
SUBCAB 4G50
SUBCAB 4G70
SUBCAB 4AWG/3-2-1-GC
SUBCAB 1AWG/3-2-1-GC
SUBCAB S3x50+3x25/3+4x1,5
SUBCAB S3x70+3x35/3+4x1,5

Shaft seals

Double mechanical shaft seals with an oil compartment between the seals.

Material lower seal: Tungsten carbide - Tungsten carbide
Material upper seal: Tungsten carbide - Tungsten carbide

Bearings

Main bearing: Two single-row angular contact ball bearing. Paired mounted

Support bearing: Cylindrical single-row roller bearing with C3 clearance

Discharge connections

N: 6" (DN 150) Flange SMS, DIN, BS or ANSI
H: 4" (DN 100) Flange SMS, DIN, BS or ANSI

Materials

Casted parts	Cast iron
Motor shaft	Stainless steel
Impeller	Cr-alloyed white cast iron or stainless steel
Screws and nuts	Stainless steel
Diffusers	Nitrile rubber

Accessories

Zinc anodes

Limitations

Max. submersion depth: 75 m
Max. liquid temperature: 40°C
Max. liquid density: 1100 kg/m³
pH of the liquid: 6-13