

PT SERIES
Self-Priming Pumps



PIONEER PUMP, INC.



Pride in Performance

High Performance Pumps, Quality People,

**When pumps are required to Perform,
Pioneer Pumps stand up to the challenge.**



**PT3050
(Diesel Package)**

Pioneer Pump builds high performance pumps at competitive prices, providing low running costs, ease of maintenance and unrivalled ability to get the job done. The PT Series self-priming pumps are no exception. Pioneer PT

Series self priming pumps are designed for reliable, efficient liquid transfer. After initial priming, they will continue to re-prime automatically. The PT Series pumps are offered in variety of configurations and metallurgies.

Features:

- Simple, reliable priming
- Special metal options
- Configurations include: frame mounted, electric package, diesel and gasoline packages
- Heavy wall construction
- Readily available

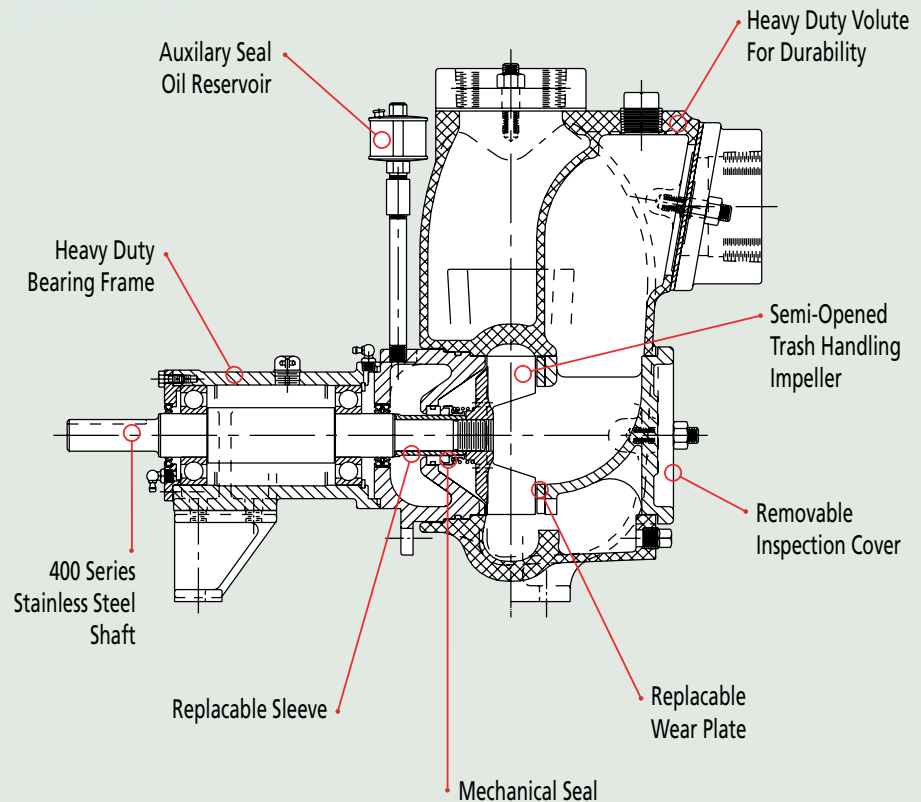

Quality Service.....Pioneer Pump!



Pioneer Pump | **PT**SERIES

Performance:

We challenge you
to compare
Pioneer's **Hydraulics**

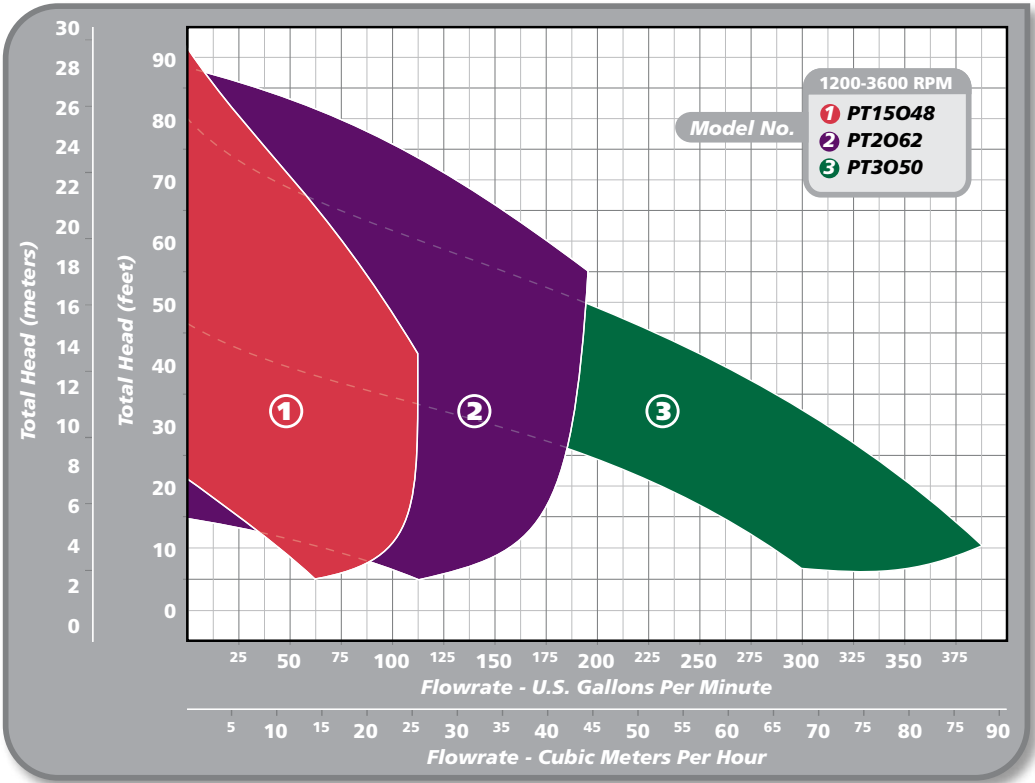

PTSeries | Standard Materials of Construction

PIONEER PT SERIES PUMPS

Part Description	Inspection Cover	Wear Plate	Impeller	Volute	Suction Check Valve	Filler Cover	Seal Housing	Mechanical Seal	Bearing Housing	Shaft	O-Rings
1 PT15048	CI	STL	DI	CI	NEO	STL	CI	SC	CI	SS	VI
2 PT2062	CI	STL	DI	CI	NEO	STL	CI	SC	CI	SS	VI
3 PT3050	DI	STL	DI	AL/DI	NEO	STL	DI	SC	DI	SS	VI

MATERIAL CODES - **AL:** Aluminum, A356 T6 | **CI:** Cast Iron, ASTM A48 Class 30 Gray Iron | **DI:** Ductile Iron, ASTM Grade 65-45-12 or 80-55-06 | **NEO:** Neoprene | **SC:** Silicon Carbide Seal Faces, Viton Elastomers, **SS:** Stainless Steel | **STL:** Steel | **VI:** Viton

The Most Complete Line Available



The Pioneer Family of Pumps



PRIME SERIES

Vacuum Assisted Run Dry, Prime From Dry, Re-Prime Pumps - Available for Solids Handling or Clear Liquid Service

Sizes: 3-18 Inch

Flows: 50-18,000 GPM

Heads: to 500+ Feet



STANDARD CENTRIFUGAL SERIES

Standard End Suction Centrifugal Available for Solids Handling or Clear Liquid Service

Sizes: 1½-18 Inch

Flows: 50-18,000 GPM

Heads: to 500+ Feet



SELF-PRIMING SERIES

Standard Self-Priming Pumps Available for Solids Handling or Clear Liquid Service

Sizes: 1½-10 Inch

Flows: 20-3500 GPM

Heads: to 200 Feet



HYDRAULIC SUBMERSIBLE & POWER UNIT SERIES

Pumps and Power units Available for Solids Handling or Clear Liquid Service

Sizes: 4-12 Inch

Flows: 200-7000 GPM

Heads: to 160 Feet



WELLPOINT SERIES

Bare Pumps or Packages Available

Sizes: 3-18 Inch

Flows: 200-18,000 GPM

Heads: to 500+ Feet

